



# Sheringham Shoal and Dudgeon Offshore Wind Farm Extension Projects Environmental Statement

## **Volume 3**

### Appendix 18.2 - Annex 18.2.1: Onshore Substation Drainage Study (Revision B) (Tracked Change Version)

March 2023

Document Reference: 6.3.18.2.1.1

APFP Regulation: 5(2)(a)

<p>Title:  <b>Sheringham Shoal and Dudgeon Offshore Wind Farm Extension Projects  DCO Application  Onshore Substation Drainage Study (<a href="#">Revision B</a>) (<a href="#">Tracked Change Version</a>)</b></p>	
<p>PINS Document no.:  6.3.18.2.1.<a href="#">1</a></p>	
<p><a href="#">Revision:</a>  <a href="#">B</a></p>	
<p>Document no.:  C282-RH-Z-GA-00190</p>	
<p>Date:                      Classification</p>	
<p><b>March 2023                      Final</b></p>	
<p>Prepared by:</p>	
<p><b>Royal HaskoningDHV</b></p>	
<p>Approved by:</p>	<p>Date:</p>
<p><del>Johiris Rodriguez Tablante</del>  <a href="#">Sheery</a>  <a href="#">Atkins</a>, Equinor</p>	<p>March 2023</p>



## Table of Contents

<b>ANNEX 18.2.1: ONSHORE SUBSTATION DRAINAGE STUDY .....</b>	<b>8</b>
<b>1 Introduction and Background.....</b>	<b>8</b>
<b>2 Onshore Substation Site Selection .....</b>	<b>9</b>
<b>3 Existing Site and Surroundings .....</b>	<b>15</b>
3.1 Ground Conditions .....	16
<b>4 Consideration of the SuDS Drainage Hierarchy .....</b>	<b>26</b>
<b>5 Assessment of Drainage Options .....</b>	<b>28</b>
5.1 Collection by Rainwater Harvesting.....	28
5.2 Discharge via Infiltration.....	28
5.3 Discharge to Surface Water Body.....	29
5.4 Discharge to a Surface Water Sewer, Highway Drain or Other Drainage System .....	32
5.5 Discharge to a Combined Sewer .....	33
5.6 Discharge via Deep Infiltration .....	36
<b>6 Proposed Drainage Solution.....</b>	<b>39</b>
<b>7 Key Surface Water Drainage Parameters .....</b>	<b>41</b>
<b>8 Conclusions .....</b>	<b>45</b>

## Table of Tables

Table 1: Ground Conditions Summary .....	18
Table 2: Groundwater Monitoring .....	19

## List of Figures

Figure 1: Site Selection Constraints Map .....	11
Figure 2: Substation Site Selection – Emerging Shortlist as presented at PEIR .....	12
Figure 3: Environmental Constraints around the Norwich Main substation .....	13
Figure 4: British Geological Survey Superficial Geology Mapping.....	16
Figure 5: Exploratory Hole Locations .....	17
Figure 6: Ditches and Hollows Local to the Onshore Substation Site .....	21
Figure 7: Anglian Water Drainage Plans for Land to the South of Hickling Lane.....	24
Figure 8: Anglian Water Drainage Plans for Land to the South and East of the Proposed Onshore Substation .....	25
Figure 9: Extract of Open Source Topography Map Showing Nearest Surface Water Body.....	31
Figure 10: Potential Option for New Pipe Connection to the River Tas .....	31
Figure 11: Anglian Water Foul Sewer Network and Order Limits.....	34
Figure 12: Indicative Topography and Contour Lines for Potential Drainage Route from Onshore Substation Site to Anglian Water Foul Sewer.....	35
Figure 13: Location of Geophysical Surveys .....	37
Figure 14: Location of the Supplementary Ground Investigation Boreholes.....	38



## Glossary of Acronyms

AONB	Area of Outstanding Natural Beauty
BGS	British Geological Survey
BH	Borehole
BRAG	Black Red Amber Green
BGL	Below Ground Level
CWS	County Wildlife Site
DCO	Development Consent Order
Defra	Department for the Environment and Rural Affairs
DEP	Dudgeon Offshore Wind Farm Extension Project
DOW	Dudgeon Offshore Wind Farm
EIA	Environmental Impact Assessment
ES	Environmental Statement
ETG	Expert Topic Group
FRA	Flood Risk Assessment
GIS	Geographical Information System
ha	Hectare
HVAC	High-Voltage Alternating Current
km	Kilometre
kV	Kilovolt
l/s	Litres per Second
LiDAR	Light Detection and Ranging
LLFA	Lead Local Flood Authority
LNR	Local Nature Reserve
LPA	Local Planning Authority
mm	Millimetres
MW	Megawatts
m/s	Metres per Second
NNDC	North Norfolk District Council
NNR	National Nature Reserve
NorCC	Norwich City Council
NCC	Norfolk County Council
NPPF	National Planning Policy Framework



NPS	National Policy Statement
NSIP	Nationally Significant Infrastructure Project
OS	Ordnance Survey
OWF	Offshore Wind Farm
PEIR	Preliminary Environmental Information Report
PPG	Planning Practice Guidance
SAC	Special Area of Conservation
SPA	Special Protection Area
SPZ	Source Protection Zone
SEP	Sheringham Shoal Offshore Wind Farm Extension Project
SNC	South Norfolk Council
SoS	Secretary of State
SSSI	Site of Special Scientific Interest
SuDS	Sustainable Drainage Systems
TP	Trial Pit
UK	United Kingdom



## Glossary of Terms

Dudgeon Offshore Wind Farm Extension Project (DEP)	The Dudgeon Offshore Wind Farm Extension onshore and offshore sites including all onshore and offshore infrastructure.
DEP onshore site	The Dudgeon Offshore Wind Farm Extension onshore area consisting of the DEP onshore substation site, onshore cable corridor, construction compounds, temporary working areas and onshore landfall area.
Evidence Plan Process (EPP)	A voluntary consultation process with specialist stakeholders to agree the approach, and information to support, the EIA and HRA for certain topics.
Expert Topic Group (ETG)	A forum for targeted engagement with regulators and interested stakeholders through the EPP.
Horizontal directional drilling (HDD) zones	The areas within the onshore cable route which would house HDD entry or exit points.
Jointing bays	Underground structures constructed at regular intervals along the onshore cable route to join sections of cable and facilitate installation of the cables into the buried ducts.
Landfall	The point at the coastline at which the offshore export cables are brought onshore, connecting to the onshore cables at the transition joint bay above mean high water
Onshore cable corridor	The area between the landfall and the onshore substation sites, within which the onshore cable circuits will be installed along with other temporary works for construction.
Onshore export cables	The cables which would bring electricity from the landfall to the onshore substation. 220 – 230kV.
Onshore Substation	Compound containing electrical equipment to enable connection to the National Grid.
Order Limits	The area subject to the application for development consent, including all permanent and temporary works for SEP and DEP.
PEIR boundary	The area subject to survey and preliminary impact assessment to inform the PEIR.
Sheringham Shoal Offshore Wind Farm Extension Project (SEP)	The Sheringham Shoal Offshore Wind Farm Extension onshore and offshore sites including all onshore and offshore infrastructure.



SEP onshore site	The Sheringham Shoal Wind Farm Extension onshore area consisting of the SEP onshore substation site, onshore cable corridor, construction compounds, temporary working areas and onshore landfall area.
Study area	Area where potential impacts from the project could occur, as defined for each individual Environmental Impact Assessment (EIA) topic.
The Applicant	Equinor New Energy Limited



## ANNEX 18.2.1: ONSHORE SUBSTATION DRAINAGE STUDY

### 1 Introduction and Background

1. The Sheringham Shoal Offshore Wind Farm Extension Project (SEP) and Dudgeon Offshore Wind Farm Extension Project (DEP) are proposed extensions to the existing Sheringham Shoal and Dudgeon Offshore Wind Farms (SOW and DOW). When operational, SEP and DEP would have the potential to generate renewable power for around 785,000 United Kingdom (UK) homes from up to 23 wind turbines at SEP and up to 30 wind turbines at DEP.
2. SEP and DEP will consist of a number of offshore and onshore elements including offshore wind turbines and subsea array cables, offshore / onshore export cables and an onshore substation to accommodate the connection to the transmission grid.
3. SEP and DEP will be connected to shore by offshore export cables installed to the landfall at Weybourne, on the north Norfolk coast. From there, the onshore export cables travel approximately 60km inland to a high voltage alternating current (HVAC) onshore substation near to the existing Norwich Main substation.
4. A site selection exercise for the onshore substation was undertaken between 2019 and 2021, which identified two potential substation site options. An assessment of these two options was presented within the SEP and DEP Preliminary Environmental Information Report (PEIR) in April 2021. Following further engineering, environmental and community feedback a preferred substation site was identified and taken forward as part of the Development Consent Order (DCO) application.
5. This document provides a summary of the site selection exercise to identify the preferred substation location and work undertaken to define flood risk management measures and drainage requirements for the preferred location.
6. As part of the submitted DCO application two drainage options were presented, comprising either a connection to the Anglian Water foul sewer or the adoption of infiltration. Following supplementary ground investigations, it has been confirmed that suitable infiltration rates can be achieved and that infiltration directly into the shallow granular zone can be adopted.
- ~~5.7.~~ On this basis, the Applicant has confirmed that the shallow infiltration solution will be taken forward as the sole drainage approach and the connection to the Anglian Water foul sewer will not be progressed further. The Applicant has submitted a non-material change at Deadline 2 and this document has been updated to reflect this approach.



## 2 Onshore Substation Site Selection

- ~~6.8.~~ An onshore substation is required to accommodate both SEP and DEP. Some of the onshore substation infrastructure may be shared between SEP and DEP and in such case the number of buildings required would be the same whether one or both projects are progressed.
- ~~7.9.~~ The following sections provide a summary of the onshore substation site selection exercise. A detailed description is set out in **ES Appendix 4.1 Onshore Substation Site Selection Report** [APP-175].
- ~~8.10.~~ The site selection process is underpinned by a series of design assumptions and site selection principles which have been used to ensure the use of a transparent framework for making site selection decisions at each stage of the site selection process.
- ~~9.11.~~ Design assumptions:
- Construction compound footprint – up to 1ha
  - Operational compound footprint – up to 6 ha
  - Building height – up to 15m
  - External equipment height – up to 30m
- ~~10.12.~~ Following the grid connection offer at Norwich Main an exercise was undertaken to identify areas with the greatest potential to accommodate the proposed permanent above ground infrastructure, taking into account the design assumptions combined with environmental constraints mapping based on publicly accessible environmental datasets, including environmental receptors and in some instances associated buffers.
- ~~11.13.~~ The guiding principles for locating the onshore substation were to identify an economic and efficient connection (i.e., as close as possible to the connection point) whilst taking into account environmental constraints and available space.
- ~~12.14.~~ A 3km buffer around the grid connection offer at Norwich Main was initially identified. Within this 3km buffer the following constraints were mapped:
- Residential properties + 250m buffer
  - Special Protection Areas (SPA)
  - Special Areas of Conservation (SAC)
  - Ramsar sites
  - Areas of Outstanding Natural Beauty (AONB)
  - Sites of Special Scientific Interest (SSSI)
  - Local Nature Reserves (LNR)
  - National Nature Reserves (NNR)
  - County Wildlife Sites (CWS)
  - Registered Parks and Gardens
  - Ancient Woodland
  - RSBP reserves



- National Trust land
- Common land
- Public Rights of Way
- Main Rivers
- Flood Zones 2 & 3
- Scheduled Monuments
- Conservation Areas
- Listed buildings
- Historic Environment Records
- Historic landfill sites
- Source Protection Zones (SPZ)
- Existing National Grid infrastructure inc. overhead lines
- Other proposed Nationally Significant Infrastructure Projects (Hornsea Project Three)

~~13.15.~~ 15. A 250m buffer was applied to residential properties to give a visual understanding of the areas where the better opportunities might be for the potential positioning of the onshore substation, i.e. areas with the greatest distance of separation to properties. **Figure 1** shows the 3km buffer surrounding the existing Norwich Main substation with these constraints mapped.

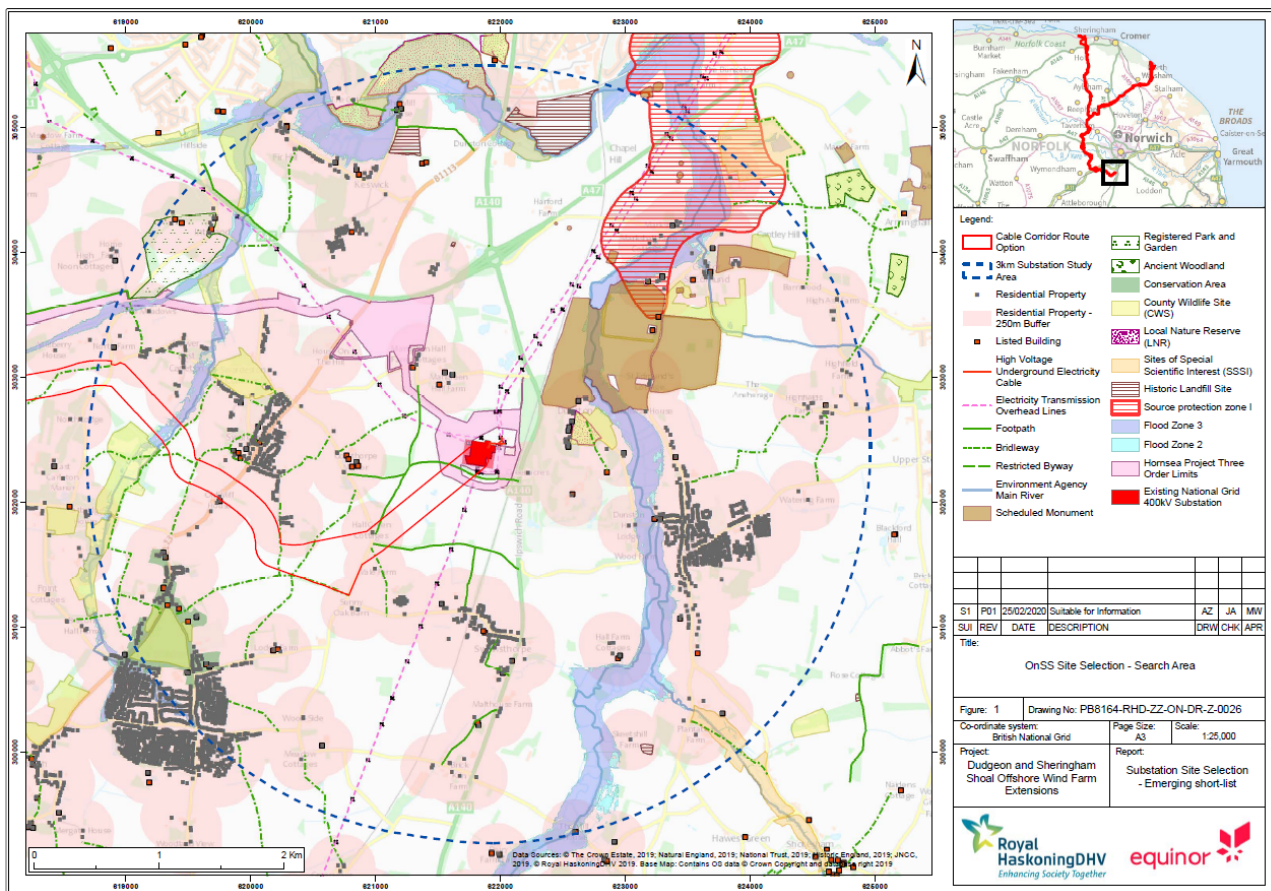
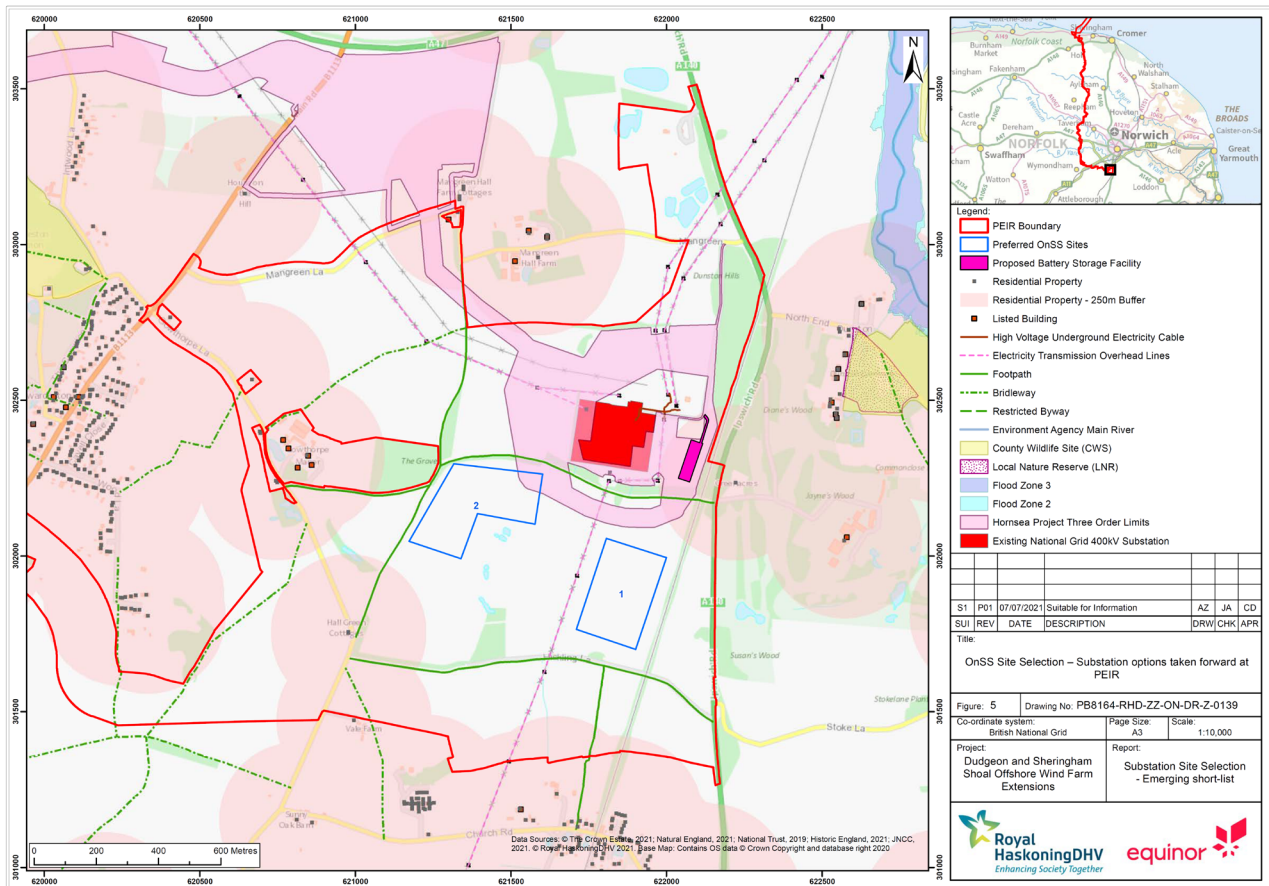

Figure 1: Site Selection Constraints Map

- 14.16.** Those areas with the least constraints and in effect the greatest potential to avoid impacts were identified as potential substation zones for further consideration. Nine zones in total were identified within the 3km buffer.
- 15.17.** A comparative assessment of these nine zones was then undertaken of which five were identified as having the greatest opportunity to accommodate the proposed infrastructure. Within these five zones a long list of 17 sites were identified that could accommodate the required substation footprint (6 ha).
- 16.18.** A BRAG assessment was undertaken for the 17 substation options, using defined BRAG criteria to identify the risks and opportunities associated with each field option. Higher risk options were given a red rating, whilst those with medium risks were coded amber and those with the least risk are assigned green. Black options were those which were not feasible from an engineering or environmental perspective. The aim was to ascertain which options carry the least risk with respect to the assessment criteria applied and based upon professional judgement.
- 17.19.** Five of the 17 locations were identified as having the fewest risks primarily based on the distance of separation between them and the nearest residential properties (typically in excess of 400m) and other visual receptors, and the relatively short distance for onward cabling for the 400kV cable connection to Norwich Main. These five locations were consulted upon during public consultation from 9<sup>th</sup> July to 20<sup>th</sup> August 2020.

**18-20.** Further engineering work and stakeholder engagement was undertaken in autumn 2020 to identify preferred locations to potentially accommodate the proposed infrastructure within the five fields taken forward. This further reduced the short list of potential sites based on insufficient space and taking into consideration the theoretical visibility from the nearest residential areas. On this basis two substation site options were identified and were assessed within the PEIR. These are identified as Site 1 and Site 2 on **Figure 2** below.



**Figure 2: Substation Site Selection – Emerging Shortlist as presented at PEIR**

**19-21.** As part of the site selection process a review of flood risk was undertaken. For the two substation sites identified at PEIR, it was noted that both are located in Flood Zone 1 and therefore are appropriately located in terms of the guidance set out in the National Planning Policy Framework (NPPF) with regard to the application of the Sequential Test.

**20-22.** Further, to this it was noted during this process that both of the two substation sites have the potential to be partially affected by or interact with the existing surface water flood risk, which would require mitigation within the design regardless of which option was selected. It is noted that the flood risk element was considered alongside the other environmental constraints, available space and stakeholder feedback. A plan of the environmental constraints around the existing Norwich Main substation is provided in **Figure 3**.

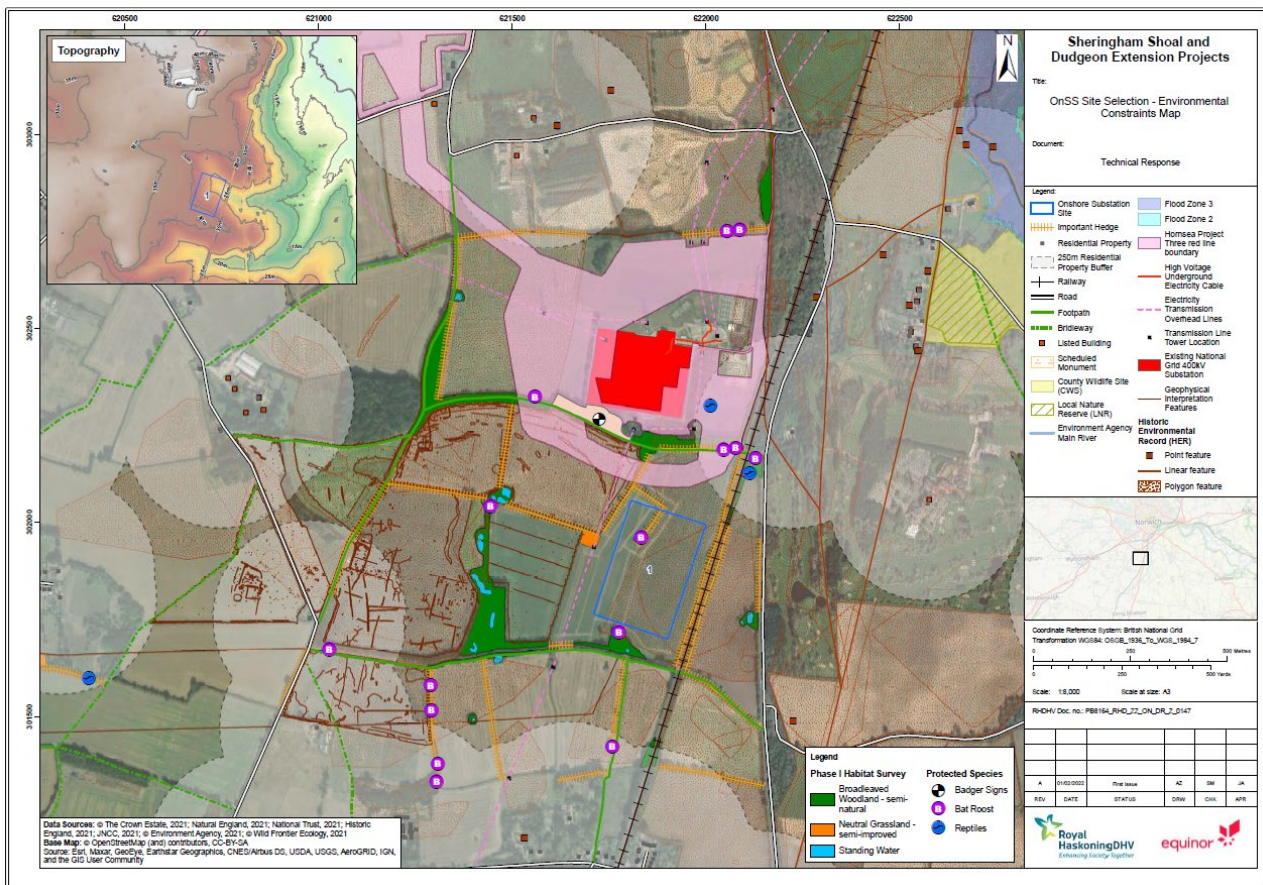

Figure 3: Environmental Constraints around the Norwich Main substation

24.23. Based on the detailed topic assessments presented within the PEIR and feedback from local communities as part of the associated consultation exercise, Site 1, as shown on **Figure 2** and **Figure 3** above, was identified as the preferred location for the onshore substation. The main benefits of this site include:

- Avoids a potential linear settlement of high heritage significance;
- Takes advantage of a natural low point within the landscape reducing its relative visibility from views across the Tas Valley;
- Positioned closer to the area most influenced by existing infrastructure including the Norwich Main Substation, pylons and overhead wires, railway lines, the A140 and A47;
- Fewer residential receptors potentially affected by operational noise prior to mitigation being applied; and
- Slight preference from community feedback.

- ~~22-24.~~ The revised NPPF (2021) provides clarification that all strategic policies / plans should apply a sequential, risk-based approach to the location of development taking into account all sources of flood risk. It also provides guidance on how this is to be considered in the context of the location of site-specific development. Further guidance, on the application of the Sequential Test and Exception Test is provided in the supporting NPPF PPG (Ministry of Housing, Communities and Local Government, June 2021).
- ~~23-25.~~ Neither the NPPF or the supporting NPPF PPG provides a set of criteria as to how the Sequential Test should be applied for sources of flooding other than fluvial or tidal, for example surface water flooding, in terms of development vulnerability and the varying level of flood risk. However, SEP and DEP has sought to adopt a precautionary approach to addressing flood risk from the outset.
- ~~24-26.~~ On this basis, following the identification of the preferred location of the onshore substation and a further review of flood risk aspects in this location, a series of initial design iterations were undertaken with regard to the siting of the onshore substation, taking into consideration the potential surface water flood risk.
- ~~25-27.~~ This approach has been discussed with the Environment Agency and Norfolk County Council, in their role as the Lead Local Flood Authority (LLFA), at a number of Expert Topic Group (ETG) meetings and has been documented separately to this study. Further details related to the surface water modelling undertaken to inform the site refinement process are provided in the **Onshore Substation Hydraulic Modelling Report** [document reference 14.34].
- ~~26-28.~~ It is anticipated that further refinement of the design will be undertaken post-DCO; however, this does not alter the conclusions of this drainage study.
- ~~27-29.~~ The purpose of this drainage study is to set out the potential options available with regard to the drainage of surface water from the onshore substation taking into consideration the need to apply the Sustainable Drainage Systems (SuDS) Hierarchy, in line with national guidance as well as local guidance set out by Norfolk County Council.

### 3 Existing Site and Surroundings

- ~~28~~30. The existing site for the proposed onshore substation comprises arable land to the south of the existing Norwich Main substation. The onshore substation site benefits from existing hedgerows and woodland blocks within the local area.
- ~~29~~31. The onshore substation site is located on sloping ground with a lower lying area located towards the north eastern corner of the area proposed for the onshore substation.
- ~~30~~32. A review of the Open Source LiDAR data for the site as well as a topographical survey obtained specifically for the projects, confirms that the site slopes from both the north and south towards approximately the centre. The highest topographical levels are located towards the southern end of the site at approximately 31m AOD, with the lowest topographical point towards the eastern boundary of the site at approximately 23.5m AOD.
- ~~31~~33. A Flood Risk Assessment (FRA) was undertaken which noted that the site proposed for the onshore substation is located in Flood Zone 1 and therefore is not at risk from fluvial or tidal flooding.
- ~~32~~34. Further to this, the potential risk from surface water, sewer, groundwater and reservoir flooding was assessed within the FRA.
- ~~33~~35. The British Geological Survey (BGS) 1:50,000 scale solid and superficial geology geological mapping was reviewed. It was noted that the onshore substation site is underlain by Chalk bedrock, which is overlain by Till superficial deposits. The Chalk bedrock is designated as a Principal Aquifer.
- ~~34~~36. The FRA noted that the onshore substation site is located outside of any areas identified to have an increased susceptibility to groundwater flooding. This accords with the information obtained during the Phase 1 Ground Investigations undertaken in September 2021, whereby the trial pit and borehole records found no evidence of groundwater down to 18m below ground level and they recorded a variable clay layer over the chalk. At the same time infiltration testing was undertaken across the onshore substation site and the wider area within the DCO Limits to understand the potential for infiltration to comprise part of the surface water drainage design. The results of the infiltration testing are discussed further in [Section 5.2](#).
- ~~35~~37. The location of the onshore substation site in a rural undeveloped area is such that flood risk from sewer flooding is unlikely to occur.
- ~~36~~38. As such, the primary source of flooding that could potentially affect the onshore substation site is from surface water flooding, as identified by the Environment Agency Flood Risk from Surface Water mapping.
- ~~37~~39. To support the understanding of surface water at the onshore substation site, a review has been undertaken of the existing greenfield runoff rates likely to be applicable to the site. This supplements the above information on the existing site as well as aiding in the development of the drainage design.

~~38.40.~~ Further to this, two-dimensional (2D) direct rainfall modelling has also been undertaken to understand the likely pathways, speed and volume of overland flow during a heavy rainfall event to aid in assessing the surface water flooding issues in greater detail. Whilst this has been considered within the context of the influence this may have on the development of the drainage design, the outputs of the modelling in relation to flood risk are considered more specifically within the FRA and in [the ~~Annex 18.2.2~~ Onshore Substation Hydraulic Modelling Report \[document reference 14.34\]](#) ~~Technical Note~~.

### 3.1 Ground Conditions

#### 3.1.1 Published Information

Published geological information has been obtained from the British Geological Survey Onshore GeolIndex [REDACTED] and indicates that the onshore substation site is predominantly underlain by superficial deposits of the Lowestoft Formation Diamicton comprising chalky till characterised by chalk and flint content with areas of outwash sand and gravels, silts and clays. One small area to the south west of the existing Norwich Main substation as depicted in pink on [Figure 4](#) is indicated to be underlain by Sheringham Cliffs formation Sand and Gravel, this is indicated to be laying directly above the Lowestoft formation.

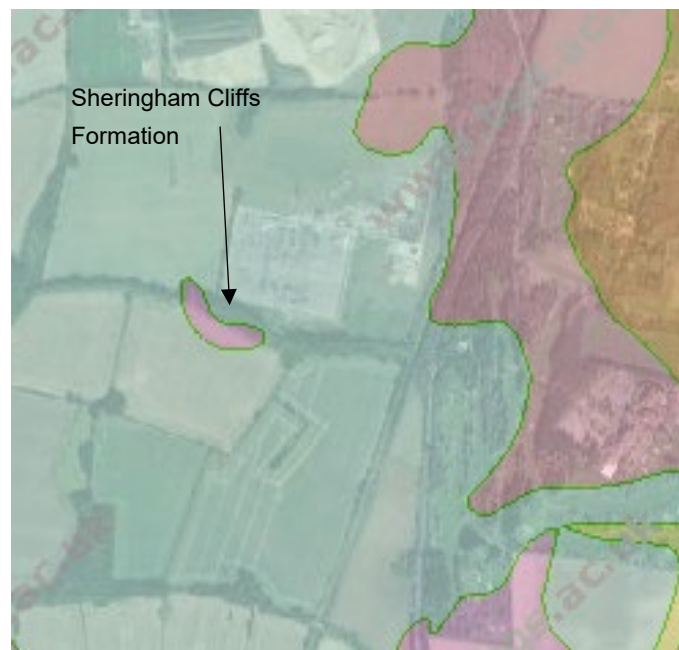

*Figure 4: British Geological Survey Superficial Geology Mapping*

~~39.41.~~ Solid geology is indicated to comprise undifferentiated Lewes Nodular Chalk Formation, Seaford Chalk Formation, Newhaven Chalk Formation, Culver Chalk Formation and Portsdown Chalk Formation of the cretaceous period.



- ~~40.42.~~ No linear features, artificial ground or mass movement deposits are recorded within 1km of the proposed onshore substation site.
- ~~41.43.~~ Five historical boreholes located on the field boundary between Norwich Main and the proposed onshore substation site have been reviewed, the results of these boreholes confirm the descriptions of the superficial deposits. ~~Further consideration of the underlying ground conditions has been summarised in the Onshore Substation Infiltration Technical Note (PB8164-RHD-ZZ-XX-NT-Z-0001-OnSS Infiltration)~~

### 3.1.2 Ground Investigation

- ~~42.44.~~ A site-specific ground investigation was scoped and undertaken during September 2021 at the proposed onshore substation site to understand the underlying ground conditions, aid in the development of the design for the substation platform and support in the determination of the soil infiltration rate. This was undertaken in accordance with BRE Digest 365 Soakaway Design (BRE, 2016).
- ~~43.45.~~ The investigation comprised six cable percussive boreholes to depths ranging between 10m and 18m below existing ground level and seven machine excavated trial pits to approximately 3.0m – 4.0m deep all with in-situ testing and sampling. The exploratory hole locations are presented as **Figure 5**. A number of the trial pits were also used for the completion of soakaway testing, as summarised later in this section.

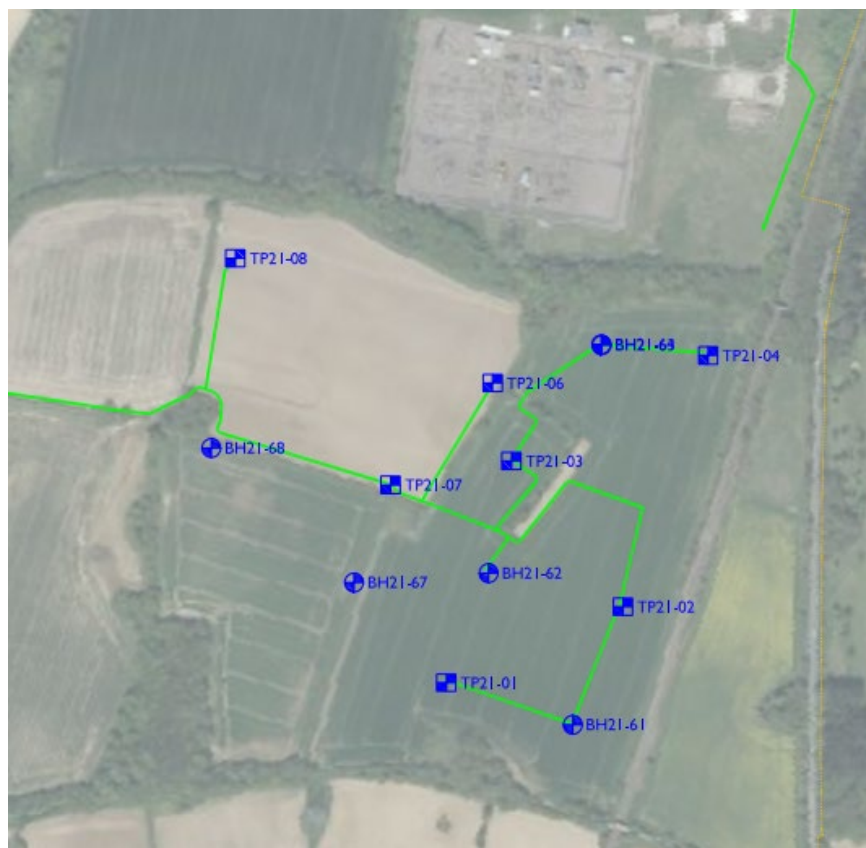

*Figure 5: Exploratory Hole Locations*

44.46. A summary of the ground conditions encountered in the exploratory holes is presented in **Table 1**.

**Table 1: Ground Conditions Summary**

Stratum	Depth to top (m BGL)	Thickness (m)	Description	Locations
Topsoil	0	0.3 to 0.9	Typically dark brown slightly clayey slightly gravelly slightly silty SAND. Gravel is rounded to angular fine to coarse flint. Occasional pockets of clay and rootlets.	All
Glacial Interbedded Clay, Silt and Sand	0.3 to 0.9	8.2 to 13.2	Predominantly: firm becoming stiff with depth orangish brown slightly sandy slightly gravelly orangish brown CLAY with a low to medium cobble content. Gravel and cobbles of subangular to subrounded flint.	BH21-62, BH21-63, BH21-64, BH21-67, BH21-68, TP21-01, TP21-02, TP21-03, TP21-04, TP21-06, TP21-08
			Occasionally: medium dense orangish brown gravelly slightly silty SAND with occasional pockets of clay. Gravel is angular to subrounded fine to coarse flint.	BH21-61, BH21-62, BH21-63, BH21-67, TP21-01, TP21-02, TP21-03, TP21-06, TP21-07
			Occasionally: firm brown slightly sandy slightly gravelly SILT with occasional medium cobble content of subangular to subrounded flint and chalk. Gravel is subangular to subrounded fine to coarse flint and chalk.	BH21-62, BH21-63, BH21-64
Glacial Gravel	1.7 to 8.5	0.7 to 2.5 (except BH21-61 three bands of 4.3m, 3.3m and 1.9m are present)	Medium dense to dense orangish brown sandy slightly silty GRAVEL with low to high cobble content. Gravel is angular to subrounded fine to coarse flint	BH21-61, BH21-62, BH21-63, BH21-64, BH21-67, TP21-02
Chalk (Lewes Nodular Chalk Formation)	4.8 to 13.5	Up to 10.8m proven	Typically recovered as a cream slightly sandy slightly gravelly SILT. Gravel described as very weak, low density with occasional subangular to subrounded flint gravel/cobbles.	BH21-61, BH21-62, BH21-63, BH21-64,



- ~~45.~~47. Geotechnical laboratory testing was undertaken on the samples recovered. The results of the testing are available with the factual report for the investigation and the test results confirmed the material descriptions.
- ~~46.~~48. Groundwater was encountered in three boreholes during the works at depths ranging from 3.7m (BH21-63) to 18m (BH21-62). Long term groundwater monitoring installations were installed in all six cable percussive boreholes, monitoring of the installations is ongoing on a monthly basis. A summary of the monitoring to date is presented in **Table 2**. Further monitoring information will be assessed as it becomes available.

*Table 2: Groundwater Monitoring*

Exploratory Hole	Response zone (m BGL)	Stratum	Highest Recorded Level (m BGL)
BH21-61	1 to 18	Glacial Deposits (Sand/Gravel) / Chalk	Dry
BH21-62	1 to 18	Glacial Deposits (Clay) / Chalk	0.12
BH21-63	1 to 18	Glacial Deposits (Sand/Gravel/Silt/Clay) / Chalk	17.7
BH21-64	1 to 18	Glacial Deposits (Gravel/Silt/Clay) / Chalk	1.59
BH21-67	1 to 10	Glacial Deposits (Gravel/Clay)	16.41
BH21-68	1 to 10	Glacial Deposits (Clay)	Dry

- ~~47.~~49. Falling head permeability testing was undertaken in BH21-67 at depths of 1.50m, 4.50m and 7.5m and in BH21-68 at depths of 1.50m, 5.50m and 9.50m. In all test locations and depths, the drop in water level was too low for ground permeability to be determined indicating low permeability.
50. In addition, soakaway testing was undertaken in accordance with BRE Digest 365 (BRE, 2016) at shallow depth in the upper Sand layer in TP21-01, TP21-02, TP21-03, TP21-06, TP21-07 & TP21-08. All tests were undertaken in pits 1.5m deep. The soakaway tests were abandoned due to a lack of infiltration into the ground over the time period that was monitored (180 – 300 minutes) because water levels had not dropped below 75% of the starting head in the majority of the test locations. As a result, infiltration rates could not be calculated because they require water level data at 75% and 25% of the starting head.
51. [In addition, to the above ground investigations, a number of supplementary investigations have been undertaken. These included obtaining further information for the area of the proposed onshore substation during a geophysical survey in April 2022 and subsequent supplementary ground investigation works in June 2022.](#)
52. [The exploratory holes installed as part of the supplementary ground investigations in June 2022 are subject to ongoing monitoring to record information related to groundwater levels.](#)

~~48.~~53. [As the data from the exploratory holes became available this has enabled the Project to review the options for the proposed surface water drainage from the onshore substation platform. The outcome of the review has informed the update of this document, with further information provided in \*\*Section 5\*\* including clarification on the proposed approach to discharge of surface water from the onshore substation platform.](#)

### 3.1.3 Surrounding Drainage Systems

~~49.~~54. The drainage systems local to the proposed onshore substation site have been assessed and these have been found to constitute three main types, comprising:

1. Field hollows / depressions
2. Agricultural field drains
3. Foul sewers (Anglian Water)

~~50.~~55. Field hollows / depressions exist along some of the field boundaries, primarily where there are trees and vegetation. The closest hollow to the proposed onshore substation is lower than the onshore substation level and is located north west of the proposed onshore substation. The volume of the hollow is relatively small in comparison to the anticipated 1 in 100 year flood water volume and wouldn't be suitable for use as the primary drainage system. Infiltration testing completed during the Phase 1 ground investigation indicated very low permeability rates, suggesting any water discharged into the hollow would not infiltrate into the ground at a fast enough rate to accommodate the 1 in 100 year flood event. Furthermore, there is no clear outfall or discharge point from the hollow to enable water to drain away from this location.

~~54.~~56. The fields surrounding the onshore substation site have a number of shallow agricultural field drains / ditches along their boundary; however, these do not connect into a downstream water body and they typically connect into a hollow / depression or simply terminate at a particular point (blind ditches). **Figure 6** was developed following a site visit and provides an illustration of the surrounding ditches and their associated depths. The yellow arrows indicate the direction of fall along the ditches. The subsequent photos provide further visual representations of the surrounding ditches and hollows with PH indicating the photograph number, as marked on **Figure 6**.





Figure 6: Ditches and Hollows Local to the Onshore Substation Site

Photo 1 - 150mm Drainage Pipe discharging into hollow



Photo 2 - Drainage Outfall in Hollow



**Photo 3 – Wet Area in Field**



**Photo 4 – Ditch 1m Deep**



**Photo 5 – 50mm Drainage Pipe**



**Photo 6 – Ditch Flume**



**Photo 7 – Ditch 0.5m Deep**



**Photo 8 – Ditch 1.5m Deep**



- ~~52-57.~~ **Figure 7** and **Figure 8** provide the asset information provided by Anglian Water following a request for drainage information for the area immediately to the south of Hickling Lane (**Figure 7**) and a wider area including land further to the south and east of the proposed onshore substation (**Figure 8**).
- ~~53-58.~~ Both search results identified the presence of foul sewer drains connected to residential / commercial properties in the village of Swainsthorpe. The foul sewer drains connect into a Pumping Station before onward transfer via a Rising Main.
- ~~54-59.~~ No storm water / surface water drains were identified as part of the searches.
- ~~55-60.~~ The information identified as part of a review of the existing drainage system [was](#) used to inform the consideration of the potential drainage options for the proposed onshore substation.

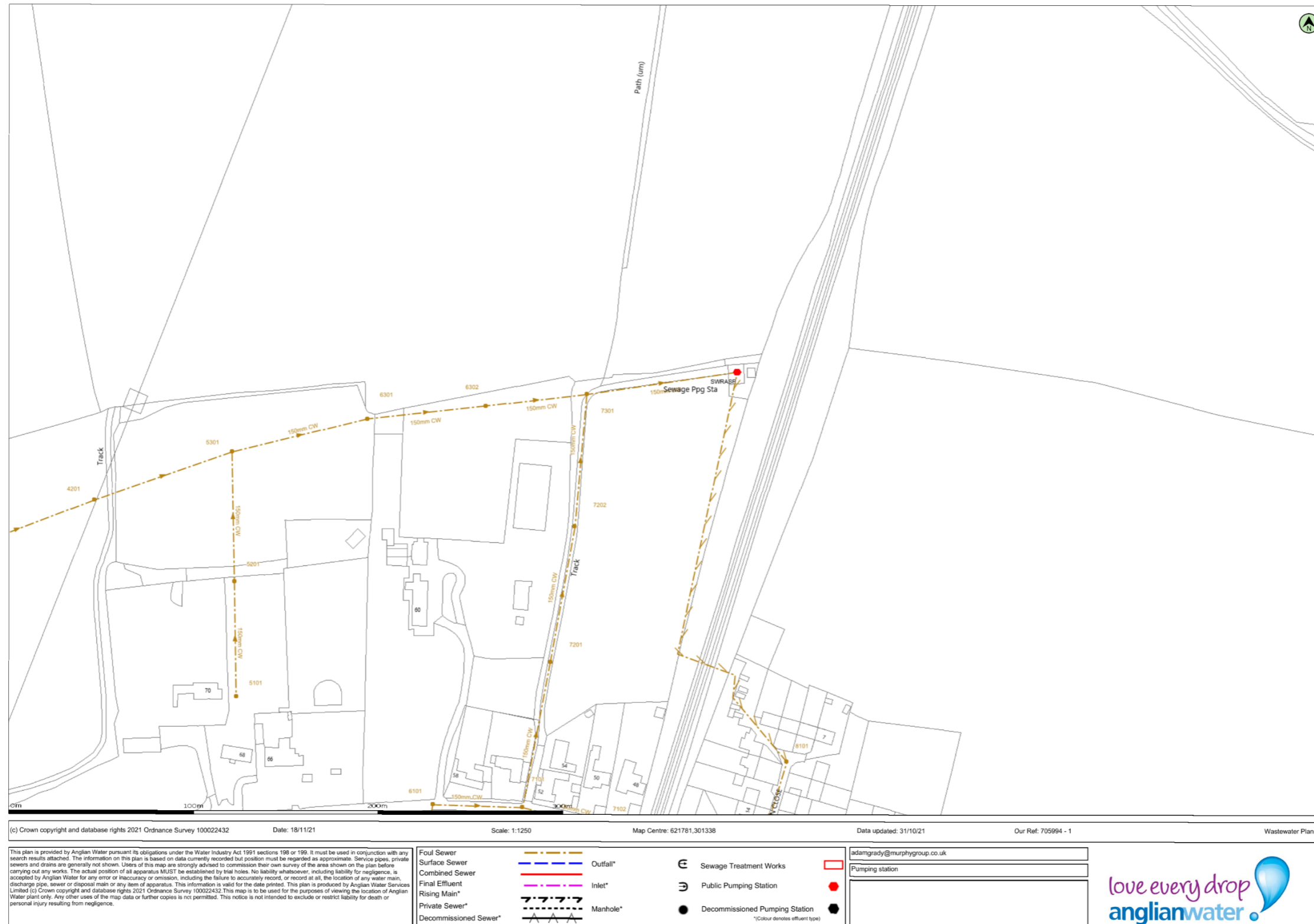
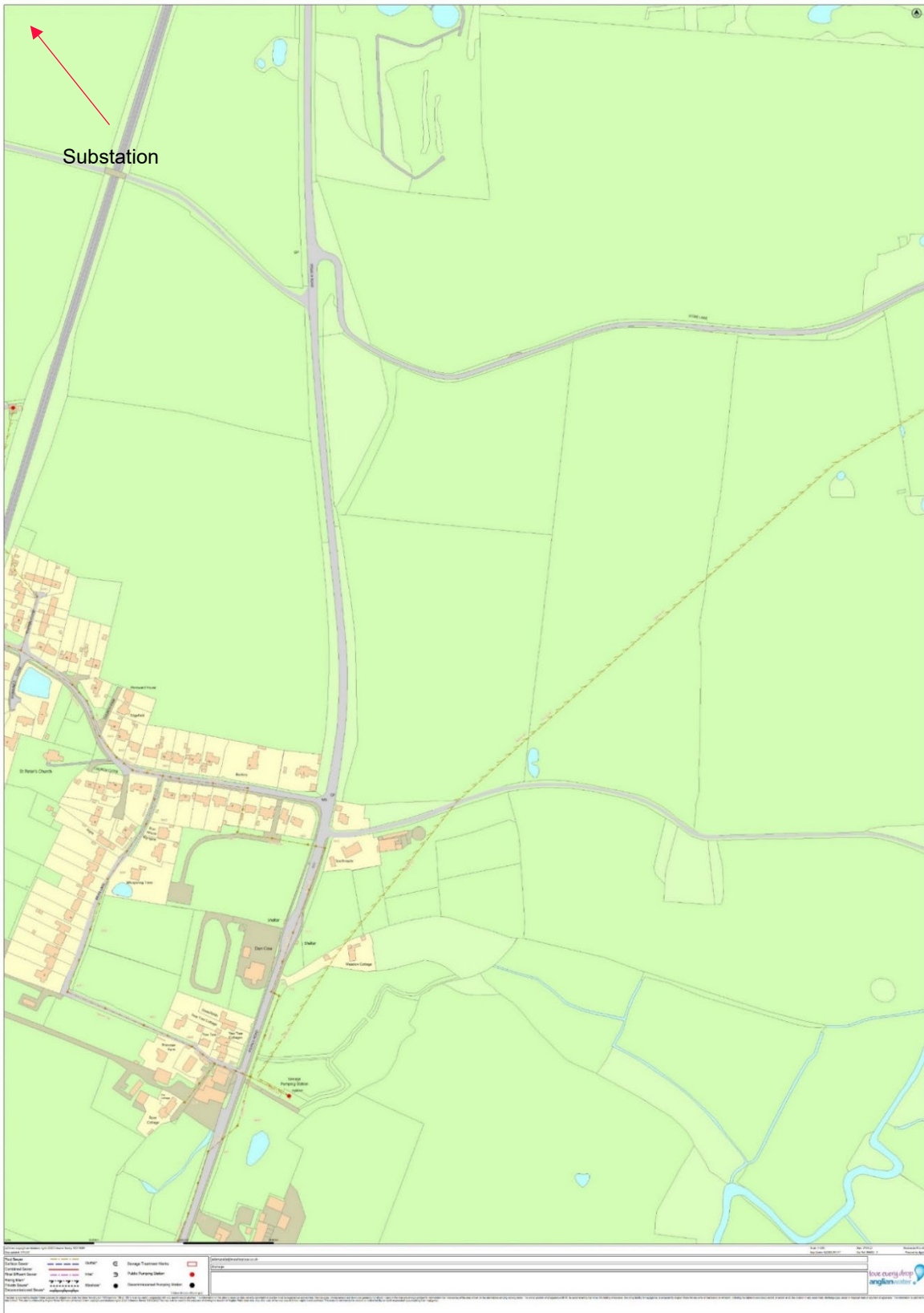

Figure 7: Anglian Water Drainage Plans for Land to the South of Hickling Lane





**Figure 8: Anglian Water Drainage Plans for Land to the South and East of the Proposed Onshore Substation**

## 4 Consideration of the SuDS Drainage Hierarchy

- ~~56-61.~~ The surface water drainage requirements for the proposed onshore substation have been considered within the context of the requirements set out in the NPPF, NPS EN-1, NPS EN-5 and the CIRIA SuDS Manual C753 (CIRIA, 2015).
- ~~57-62.~~ Furthermore, reference has also been made to the guidance set out in the Norfolk County Council (NCC) *Lead Local Flood Authority (LLFA) Statutory Consultee for Planning Guidance Document, Version 65.1, October 2022*~~4~~ (hereafter referred to as the NCC Guidance Document). This document sets out their planning policy in relation to flood risk and surface water drainage as well as providing guidance on the information they require to provide an appropriate response to major planning applications.
- ~~58-63.~~ Information set out in the NCC Guidance Document has been considered in the context of the projects and specifically within the context of addressing flood risk and surface water drainage at the onshore substation site.
- ~~59-64.~~ Of specific reference to this drainage study and the proposed location of the onshore substation site is the guidance set out in Paragraph 10.2.1 which notes:
- “In the case of surface water overland flow routes, if the areas cannot be avoided, sufficient information should be provided to demonstrate how this overland flow route will be managed within the site without creating a risk to people or property and not increasing the risk elsewhere.”*
- ~~60-65.~~ This has been considered through the development of the 2D direct rainfall modelling, as noted in **Section 3** above. Further details of this are also provided in the [Flood Risk Assessment \[AS-023\]](#) and [Onshore Substation Hydraulic Modelling Report \[document reference 14.34\]](#) ~~as part of the DCO application.~~
- ~~64-66.~~ Whilst the above considers the surface water flood risk to the onshore substation site it is necessary to consider the requirement to control and attenuate the discharge of surface water from the site itself, as a result of the increased impermeable area introduced by the onshore substation platform itself. This is to ensure that the increased impermeable area does not result in an increased flood risk as a result of the development.
- ~~62-67.~~ Surface water drainage has been considered within the context of Paragraph 11.~~23~~ of the NCC Guidance Document:
- “It should clearly be demonstrated in any submission how the proposals follow the NPPF hierarchy (Policy Box 2). Adequate justification and evidence will be required should surface water be proposed to be discharged using methods lower down the hierarchy than infiltration. We expect that at least one option is demonstrated to be feasible, can be adopted and properly maintained and would not lead to any other environmental problems.”*
- ~~63-68.~~ Policy Box 2 of the NCC Guidance Document has been reproduced below. It is noted that this guidance is in accordance with the SuDS Drainage Hierarchy set out in the NPPF Planning Practice Guidance (June 2021) and also in the CIRIA (C753) SuDS Manual.

**Policy Box 2: NPPF Drainage Hierarchy**

National Planning Policy Framework Flood Risk and Coastal Change Planning Practice Guidance

*“Generally, the aim should be discharge surface runoff as high up the following hierarchy of drainage options as reasonably practicable:*

1. Into the ground (infiltration);
2. To a surface waterbody;
3. To a surface water sewer, highway drain or another drainage system;
4. To a combined sewer.”

[Paragraph: 080 Reference ID: 7-080-20150323]

~~64.~~69. Further to this, the NCC Guidance Document also references the Water UK Design and Construction Guidance (March 2020), within Policy Box 3 (reproduced below). It also identifies there should be a further consideration for collection of water at the top of the SuDS Drainage Hierarchy comprising the collection of rainwater for use within rainwater harvesting.

**Policy Box 3: DCG Drainage Hierarchy**

Water UK Design and Construction Guidance – Sewerage Section Guidance Appendix C.

*“The government guidance to local authorities includes a hierarchy of connection, which can be summarised as follows:*

- a. Surface water runoff is collected for use;
- b. Discharge into the ground via infiltration;
- c. Discharge to a watercourse or other surface waterbody;
- d. Discharge to a surface water sewer, highway drain or another drainage system discharging to a watercourse or other surface waterbody;
- e. Discharge to a combined sewer.”

[Appendix C: Section C3: Paragraph 12]

~~65.~~70. Paragraph 11.7 of the NCC Guidance Document notes that:

*“At least one feasible proposal for the disposal of surface water drainage should be demonstrated and, in all cases, supported by the inclusion of appropriate evidence.”*

~~66.~~71. It goes on to note that infiltration should be considered first for the disposal of surface water drainage, supported by infiltration testing and that only if this is unfavourable it is appropriate to work down the SuDS Drainage Hierarchy.

~~67.~~72. It is within this context that the following sections of this report, set out each of the elements of the SuDS Drainage Hierarchy demonstrating how each of these has been considered when identifying a solution for the discharge of surface water drainage from the onshore substation site.



## 5 Assessment of Drainage Options

### 5.1 Collection by Rainwater Harvesting

- ~~68-73.~~ 73. As noted above, Norfolk County Council is part of Water Resources East, and has adopted the consideration of the use of water for rainwater harvesting in their SuDS Drainage Hierarchy prior to the consideration of infiltration.
- ~~69-74.~~ 74. It is noted that collection of rainwater, whilst feasible is likely to have little impact in reducing the quantities of water to be discharged from the onshore substation site during an event. There is no specific requirement for water in the operation and maintenance of the onshore substation site and the potential for the reuse of collected water within the site is low.
- ~~70-75.~~ 75. Current proposals are that the proposed onshore substation is an unmanned facility. Minimal rainwater harvesting could be incorporated into areas of the onshore substation where a requirement for grey water is identified, such as welfare facilities, but the demand is likely to be low and there is likely to be little benefit from harvesting.
- ~~71-76.~~ 76. On its own, it is anticipated that this drainage option would not fulfil requirements in terms of draining the onshore substation. Although potential opportunities exist for partial reuse of rainwater harvesting, it would need to ~~should~~ be considered within the context of combining this with another method of discharge from the [proposed onshore substation site](#).

### 5.2 Discharge via Infiltration

- ~~72-77.~~ 77. In line with the SuDS Drainage Hierarchy, ~~initial~~ consideration was ~~has been~~ given to the discharge of water through the most sustainable SuDS solution, i.e. aiming for an option as high up the SuDS Drainage Hierarchy as possible.
- ~~73-78.~~ 78. To assess the potential of adopting a SuDs solution, infiltration testing in accordance with the requirements of BRE Digest 365 Soakaway Design (BRE, 2016) was ~~has been~~ undertaken at various locations across ~~on~~ the proposed onshore substation site, as shown by locations prefixed by 'TP' on **Figure 5**. Testing was undertaken during late August / early September 2021.
- ~~74-79.~~ 79. At each location the test pit was machine excavated to 1.5m depth, no pit stability issues were noted and gravel filling of the pits was not required.
- ~~75-80.~~ 80. All pits were filled and monitored for between 3 and 5 hours, with the water level monitored at regular time intervals. In four of the six locations 75% head was not achieved. In the remaining two pits whilst 75% head was reached the 25% head level was not reached. Due to the slow rate of drain down in the pits an infiltration rate was not able to be determined indicating that drainage of the proposed onshore substation via infiltration wa~~s~~ is not likely to be feasible.
- ~~76-81.~~ 81. In addition, falling head permeability testing was undertaken in two boreholes BH21-67 & BH21-68 at 1.50m, 4.50m, 5.50m, 7.50m and 9.50m depth. All tests were monitored for a period of 60 minutes. The rate of the drop of water in the test section was insufficient to calculate permeability indicating permeability to be low.

- ~~77-82.~~ The use of infiltration at this stage was not ruled out. Further information was obtained for the area of the proposed onshore substation during a geophysical survey undertaken in April 2022 and subsequent supplementary ground investigation works, in June 2022.
- ~~78-83.~~ During the geophysical survey it was noted that there is a potential buried glacial channel present across the onshore substation site. This appears to link with the results from the initial survey for BH21-61, which may be representative of its characteristics. The location of the buried glacial channel indicates an area which is ~~likely to be~~ more permeable in nature. The remaining soils across the onshore substation site are likely to be more cohesive in nature i.e. comprising clays and silts and therefore they are likely to be less permeable in nature.
- ~~84.~~ In the second phase of supplementary investigations the areas which were not previously subject to testing were targeted. The location for these were identified taking into consideration the results of the geophysical surveys undertaken in April 2022.
- ~~79.~~ ~~On this basis, f~~Further opportunities to adopt infiltration as the potential SuDS solution for the onshore substation continued to be investigated. Until such time as this ~~can~~ could be confirmed as a viable option, other SuDS solutions ~~were will~~ also ~~continue to be~~ considered in parallel. This review of ~~alternative suitable~~ options is summarised in the following sections of this Onshore Substation Drainage Study.
- ~~85.~~ ~~However, SEP and DEP are committed to adopting infiltration as an option should this provide to be a viable solution for the surface water drainage from the onshore substation.~~ Following the installation of exploratory holes, as part of the supplementary ground investigations in June 2022, these ~~have been~~ are subject to ongoing monitoring to record information related to groundwater levels.
- ~~80-86.~~ This ongoing monitoring, as well as the additional information obtained during the supplementary ground investigations, has enabled the Applicant to review the options available for the discharge of surface water from the onshore substation platform, from those presented in Annex 18.2.1 - Onshore Substation Drainage Study (Revision A) [APP-210]. This has led to the identification of the revised approach as summarised in Section 6, which is in accordance with the SuDS Drainage Hierarchy.

### 5.3 Discharge to Surface Water Body

- ~~81-87.~~ As set out in **Section 3.1.3** and shown in **Figure 6**, a site walkover was undertaken in the vicinity of the proposed onshore substation. The site walkover confirmed the presence of agricultural field drains but there was no onward connectivity to other waterbodies and the ditches were either blind or connected into a hollow / depression with no clear outfall or discharge point.
- ~~82-88.~~ On this basis, the search was widened to include other areas surrounding the onshore substation site, including land to the east of the railway line and A140. This introduced a number of additional agricultural field drains and hollows but again none of these are connected to a water body as shown in **Figure 9** below.
- ~~83-89.~~ The closest surface water body that connects to the River Tas is a field drain approximately 1.5km southeast of the proposed onshore substation site (as the crow flies).

- 84.90.** The red circle in **Figure 9** shows the start of the field drain that connects to the River Tas. However, a review of the topography between the proposed onshore substation site and the start of the drainage network [noted that this](#) is not a continual downward gradient.
- 85.91.** To the south of the proposed onshore substation site the topography increases as it passes over Hickling Lane (i.e. the lane runs along a relative high point) before it then reduces in elevation further to the south. The topography then increases in elevation again on the approach to Swainsthorpe. To the east of Swainsthorpe the topography then gradually reduces in elevation towards the River Tas.
- 86.92.** A review of this route to connect the proposed onshore substation drainage to the River Tas would involve the construction of a new below ground pipeline approximately 2km long with multiple trenchless crossings to pass under the railway line as well as the A140.
- 87.93.** ~~At the current time~~ it is considered that the cost and environmental impact of installing a new pipeline to connect to the River Tas is not feasible given the distance to the closest water body connection, variation in topography, technical complexity and number of landowners that would need to be consulted with in order to make the connection.
- 88.94.** On this basis, this option has not been considered further with regard to the provision of surface water drainage from the proposed onshore substation.

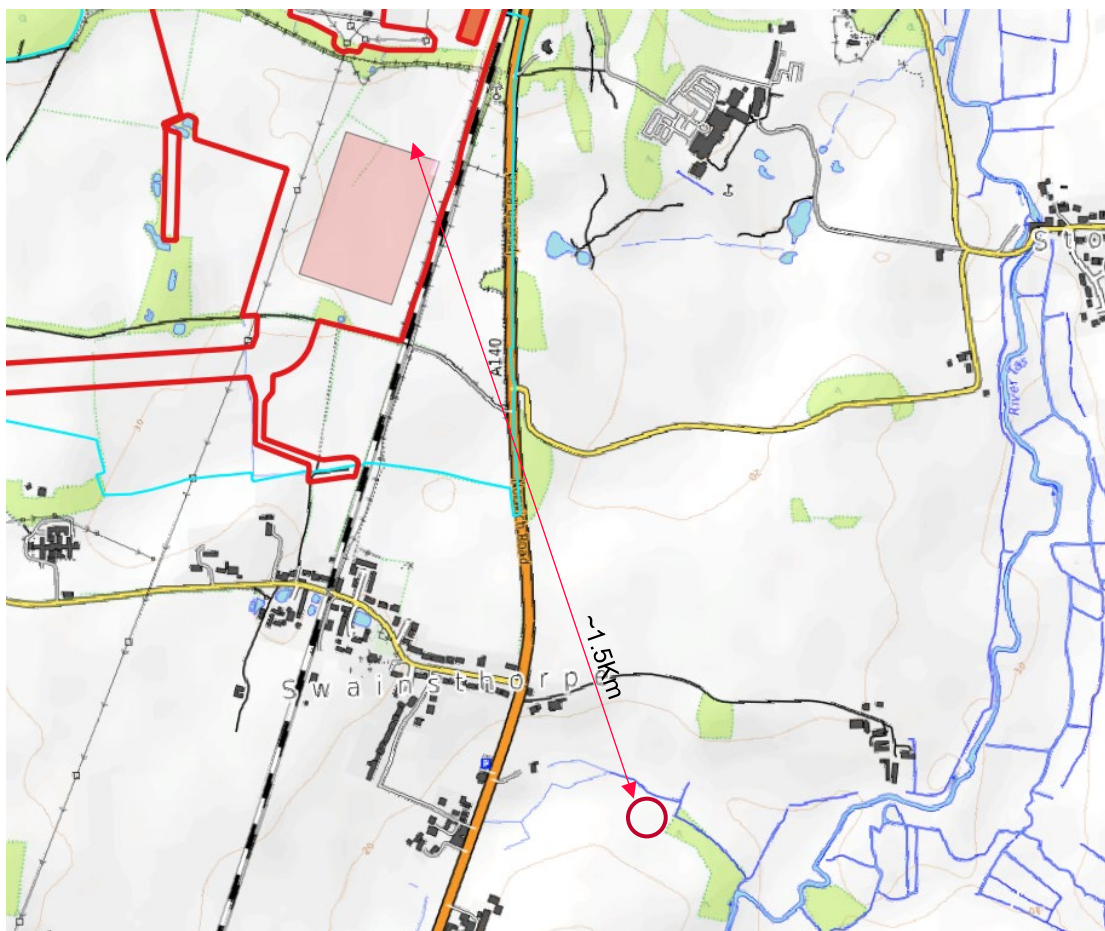

**Figure 9: Extract of Open Source Topography Map Showing Nearest Surface Water Body**

- 89.95.** The closest drainage network that could potentially be combined and connected to the River Tas comprises a series of ponds and ditches within Dunston Hall Golf Club. To provide connectivity the ditches and ponds within the golf course would need to be connected by new sections of pipe to be installed through the golf course. It is likely this option would introduce a significant amount of resistance from the owners and members of the golf course.
- 90.96.** Furthermore, and similar to the constraints associated with the new pipeline outlined above, to connect the proposed onshore substation site to the River Tas would involve the construction of a new below ground pipeline with multiple trenchless crossings to pass under the railway line as well as the A140.
- 94.97.** On this basis, the option of connecting via Dunston Hall Golf Club has been discounted due to its sensitivity as well as the cost and environmental impact that would result from installing a new pipeline and connecting the existing ponds and ditches,
- 92.98.** There remains one other potential option for connecting the surface water drainage from the proposed onshore substation into the River Tas comprising a new pipeline to be installed immediately east of the proposed onshore substation site as shown in **Figure 10**.

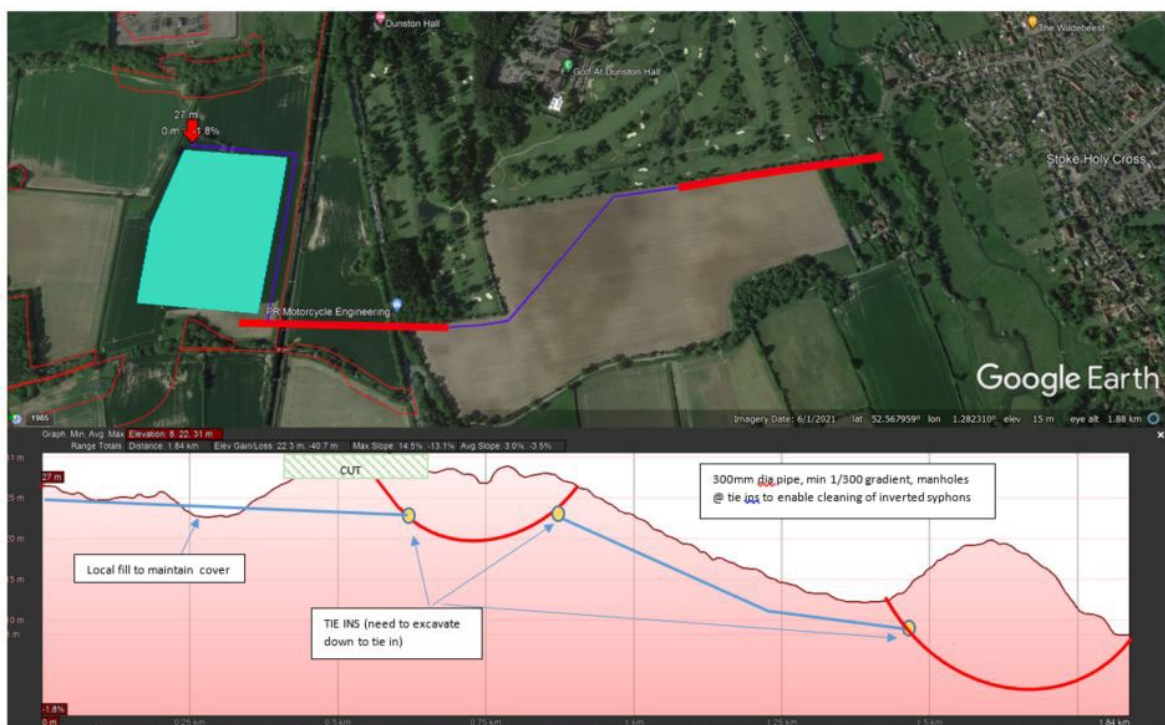

**Figure 10: Potential Option for New Pipe Connection to the River Tas**

- 93.99.** Following a site visit, on 2<sup>nd</sup> February 2022, to determine the feasibility of the proposed pipeline route identified in **Figure 10**, it was noted that the end of the pipeline would need to be located within an area of marshland / wetland.

- ~~94.~~[100.](#) Works to provide a head wall for the outfall would need to be undertaken on the bank of the river in the wetland area which is likely to introduce complications for construction as well as issues associated with access to install and / or maintain the outfall structure.
- ~~95.~~[101.](#) **Figure 10** shows that this option would also involve the construction of a new below ground pipeline with multiple trenchless crossings to pass under the railway line as well as the A140. In addition, due to the elevation changes in some locations along the route there would need to be a localised fill exercise to maintain sufficient cover over the pipe as well as deeper excavation to pass under areas where the topography is elevated.
- ~~96.~~[102.](#) Therefore, the option of connecting via a pipeline directly to the east of the proposed onshore substation site has been discounted due to the cost and environmental impact that would result from installing a new pipeline and connection to the River Tas.
- ~~97.~~[103.](#) On this basis, the option to connect to an existing surface water body has not been considered further with regard to the provision of surface water drainage from the proposed onshore substation.

#### 5.4 Discharge to a Surface Water Sewer, Highway Drain or Other Drainage System

- ~~98.~~[104.](#) As noted in **Section 3.1.3** a drainage search was undertaken for the area immediately to the south of Hickling Lane as well as a wider search of the land further to the south and east of the proposed onshore substation.
- ~~99.~~[105.](#) The results from both of these searches identified the presence of foul sewer drains connected to residential / commercial properties in the village of Swainsthorpe. However, no surface water sewers were identified as part of the searches.
- ~~100.~~[106.](#) On this basis, it is considered that there is no existing surface water sewer into which the proposed onshore substation surface water drainage can discharge.
- ~~101.~~[107.](#) The potential for a drainage connection into the highway drainage has also been assessed. Email correspondence with Norfolk County Council, in their role as the Highway Authority, has been undertaken to understand both the presence of any highway drainage in the local area, as well as their position with regard to a potential connection.
- ~~102.~~[108.](#) Email correspondence from the Highway Authority, dated 12<sup>th</sup> April 2022, confirmed the following:

*“The Highway Authority does not allow third parties to connect into its drainage system. Any spare capacity that may exist is specifically reserved for future highway use.*

*Other than confirming there will be some road gulleys along the A140 and they most likely discharge into the watercourses along this road, the local engineer has no details of the existing system. The local engineer has advised me that he is not aware of any drainage along Hickling Lane, other than grips in the verge and back ditches. If you need to see details, you would need to arrange your own survey, but as we would not permit you to connect anyway, I do not see that as something worth progressing.”*



~~103.~~109. From the site visits undertaken to date no evidence of highway drainage has been identified along Hickling Lane. Furthermore, there appear to be limited gully's on the A140 which are likely to discharge into the watercourses or ditches alongside the road, in accordance with the information provided by the Highway Authority. It is also noted that these watercourses or ditches appear to be blind ditches and therefore there would be no onward connectivity to the River Tas, or any other watercourse, during an event.

~~104.~~110. Additionally, as the Highway Authority has a policy that does not allow connection into their drainage system then it is considered that this is not a viable option for the surface water drainage from the proposed onshore substation.

~~105.~~111. A review of the mapping in **Figure 9**, as well as the information obtained during site visits, indicates there are no other drainage systems in the local area into which the proposed onshore substation could discharge its surface water.

~~106.~~112. On this basis, the option to connect to an existing surface water sewer, highway drain or other drainage system is not considered further with regard to the provision of surface water drainage from the proposed onshore substation.

## 5.5 Discharge to a Combined Sewer

~~107.~~113. As noted in **Section 3.1.3** a drainage search was undertaken for the area immediately to the south of Hickling Lane as well as a wider search of the land further to the south and east of the proposed onshore substation. The results of this search are presented in **Figure 7** and **Figure 8**. The results of this search confirmed there are no combined sewers in the local area of the proposed substation site. As such the search was widened to also consider the presence and location of foul sewers.

~~108.~~ **Figure 11** below shows the location of the closest Anglian Water foul sewer network, which has been overlaid with the [Pproject](#) and the [Order DCO-Limits at the time of the application](#). The red dot shown on **Figure 11** comprises the Anglian Water Pumping Station, brown dots are the location of manholes, and the brown dashed line is the 150mm diameter foul sewer pipe.

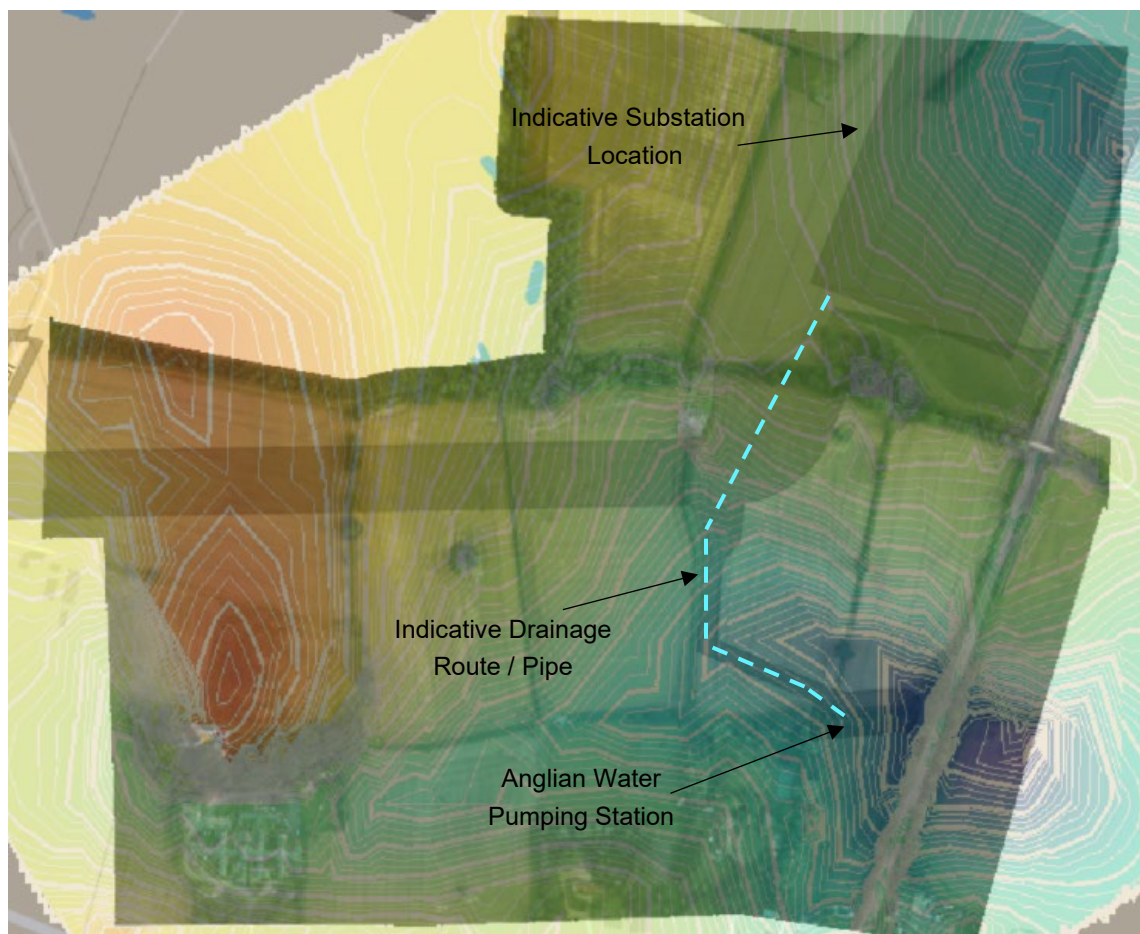

Figure 11: Anglian Water Foul Sewer Network and [Order Limits](#)

~~109.114.~~ A review of the location of the proposed onshore substation ~~was~~ ~~has been~~ undertaken alongside the identification of the Anglian Water foul sewer network. **Figure 12** below shows a potential route for a drainage pipe that could connect the proposed onshore substation to the Anglian Water foul sewer network. Both ends of the drainage route are located within an area of relatively low elevation as indicated by the blue colours, whilst the green colours in the intervening area, especially around Hickling Lane, indicate higher elevations.

~~110.115.~~ If the drainage pipe ~~were is~~ to be developed as a gravity based solution then a falling gradient will need to be maintained along the full length of the pipe. This ~~would~~ ~~will~~ result in the pipe being buried much deeper below ground in the elevated locations, typically up to 8m in depth.

~~111.116.~~ If an open cut solution ~~were is~~ to be adopted then a significant trench would need to be constructed to install the pipe. Alternative solutions may involve the use of deep trenching machines which are capable of installing drainage pipes to this depth. A trenchless crossing under Hickling Lane would be required, this is likely to create an inverted syphon that would require access for maintenance / cleaning.



*Figure 12: Indicative Topography and Contour Lines for Potential Drainage Route from Onshore Substation Site to Anglian Water Foul Sewer*

- 142.117.** From a review of the topographical levels the invert level of a new drainage pipe at the proposed onshore substation would likely be approximately 24m AOD. The invert level of the Anglian Water foul sewer at a potential connection point is likely to be approximately 22.6m AOD. Therefore, the fall in elevation between the start of the drainage pipe and the invert level of the foul sewer is likely to be approximately 1.4m.
- 143.118.** Based on the use of a 300mm diameter pipe with a 1 in 300 gradient over a distance of 1,030m (which is the approx. length of the drainage pipe), the required difference in elevation to maintain flow is likely to need to be approximately 3.4m.
- 144.119.** Therefore, to maintain sufficient gradient to continually discharge water through the drainage pipe the connection point to the Anglian Water foul sewer would need to be revised. Additionally, upgrade works would be required to the existing foul sewer to accommodate the connection of the new 300mm diameter pipe.

~~120.~~ On this basis, whilst this solution continues to be progressed as a feasible option for the discharge of surface water from the proposed onshore substation, other options ~~continue to be~~ also considered alongside it, as presented in Annex 18.2.1 - Onshore Substation Drainage Study [APP-210]. ~~, as set out in the following section~~

~~115.~~121. The Applicant notes that as part of the non-material change, at Deadline 2, the Order Limits are subject to amendment to remove the connection to the Anglian Water foul sewer. This is in accordance with the adopted approach to the discharge of surface water from the onshore substation platform. Further details related to the adopted approach are provided in Section 6 and Section 7.

## 5.6 Discharge via Deep Infiltration

~~116.~~122. During meetings with Norfolk County Council, in their role as the LLFA, surface water drainage within the area was discussed. It was noted that there are limited options available for surface water drainage from the proposed onshore substation.

~~117.~~123. During these discussions it was identified that, following the principles of the SuDS Drainage Hierarchy, i.e. working from the top towards the bottom to find the most feasible, the only potential option ~~currently~~ considered to be viable was discharge into the Anglian Water foul sewer.

~~118.~~124. On the basis that this option is not specifically identified within the SuDS Drainage Hierarchy the discussion with Norfolk County Council also noted that consideration should be given to the use of deep infiltration techniques for the surface water drainage,

~~119.~~125. It is acknowledged that this is not a preferred option to be accepted by the LLFA, however, it was noted that options are limited and therefore it should be considered for its applicability.

~~120.~~126. As a result, the opportunity to utilise deep infiltration techniques ~~is to be~~ was considered alongside the option to discharge water into the Anglian Water foul sewer.

~~121.~~127. A desk-based review of the Phase 1 ground investigation / surveys carried out in the latter part of 2021 ~~has been~~ was undertaken to obtain an understanding of the underlying ground conditions. The results of this were presented to the Environment Agency and LLFA in a Ground Investigation Technical Note (PB8164-RHD-ZZ-XX-NT-Z-0003-OnSS Infiltration).

~~122.~~128. Subsequent to the initial preparation of this Technical Note, a series of geophysical surveys were undertaken in April 2022. The location of the geophysical surveys is summarised in **Figure 13**. ~~The Technical Note has been updated to include a summary of the results of the geophysical surveys.~~

~~123.~~129. The geophysical surveys comprised a series of electromagnetic and resistivity measurements, with the resistivity lines located to tie in with the boreholes from the ground investigation campaign undertaken in 2021.



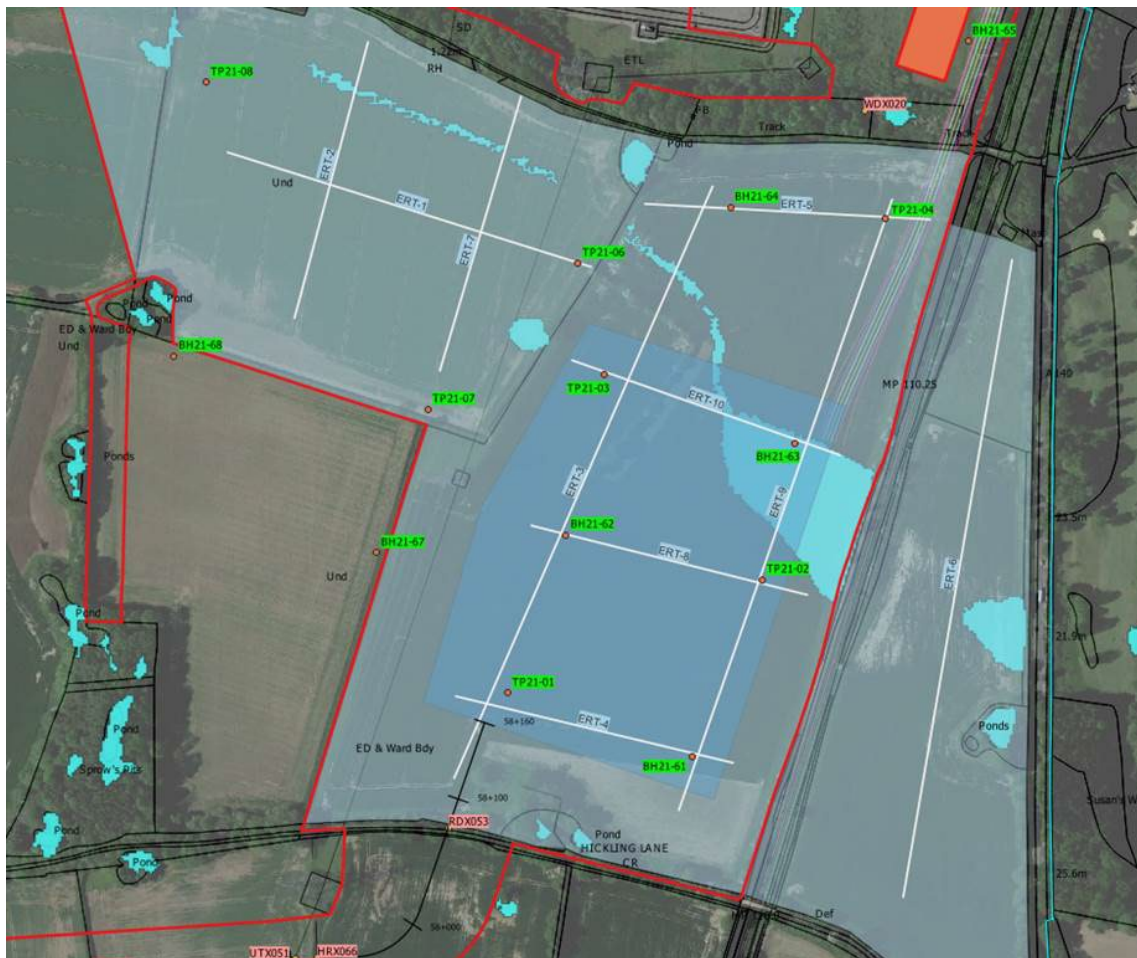

Figure 13: Location of Geophysical Surveys

- ~~124.~~[130.](#) The results of these surveys have been reviewed alongside the previous ground investigations to obtain an improved understanding of the sub-surface features. As noted in [Section 5.2](#), the geophysical surveys noted the presence of a potential buried glacial channel across the onshore substation site. This appears to link with the results from the initial survey for BH21-61. The location of the buried glacial channel indicates an area which is likely to be more permeable in nature.
- ~~125.~~[131.](#) However, the geophysical surveys found that the remaining soils across the onshore substation site are likely to be more cohesive in nature i.e. comprising clays and silts and therefore they are likely to be less permeable in nature.
- ~~126.~~[132.](#) The results of the above geophysical surveys were used to inform the scope and locations to be considered further within the supplementary ground investigations which were undertaken in June 2022.
- ~~127.~~[133.](#) In the supplementary ground investigations undertaken in June 2022 three cable percussive boreholes, namely BH21-71, BH21-72 and BH21-73 were located within the potential granular channel and a further cable percussive borehole, BH21-74 was located within another potential granular area, shown on [Figure 14](#).



Figure 14: Location of the Supplementary Ground Investigation Boreholes

134. As noted in **Section 5.2**, the geophysical surveys and supplementary ground investigations, have been undertaken to assess the viability of deep infiltration for the discharge of surface water from the proposed onshore substation. These boreholes ~~continue to be~~ are subject to ongoing monitoring ~~to understand the potential for deep infiltration or, where appropriate, shallow infiltration to be adopted for surface water drainage from the onshore substation.~~

~~128.~~135. This ongoing monitoring, as well as the additional information obtained during the supplementary ground investigations, has enabled the Project to review the options available for the discharge of surface water from the onshore substation platform, from those presented in Annex 18.2.1 - Onshore Substation Drainage Study (Revision A) [APP-210]. This has led to the identification of the updated approach as summarised in Section 7-8 which is in accordance with the SuDS Drainage Hierarchy.

## **6 Proposed Drainage Solution**

136. The outcomes of **Annex 18.2.1 - Onshore Substation Drainage Study (Revision A)** [APP-210] were used to develop the **Outline Code of Construction Practice (Revision B)** [REP1-023] and the **Outline Operational Drainage Plan (Onshore Substation)** [APP-307], submitted as part of the application.
137. Within the original application, two approaches to the discharge of surface water drainage were presented in **Annex 18.2.1 - Onshore Substation Drainage Study (Revision A)** [APP-210] based on the option for either a connection to the Anglian Water foul sewer or the adoption of deep infiltration.
138. As noted in **Section 3.1.2**, a number of supplementary investigations have been undertaken. These included obtaining further information for the area of the proposed onshore substation during a geophysical survey in April 2022 and subsequent supplementary ground investigation works in June 2022.
139. Furthermore, the exploratory holes installed as part of the supplementary ground investigations in June 2022 are subject to ongoing monitoring to record information related to groundwater levels.
140. The initial ground investigations in 2021 provided results showing no water within the boreholes. In addition, the geophysical surveys in April 2022 identified shallow granular zones potentially suitable for infiltration. The survey noted that these appear to be linked to a historic river channel that had been infilled with granular deposits to a depth of approximately 10m.
141. As part of the supplementary groundwater investigations, three boreholes were bored to ground truth the geophysical surveys. Each borehole included a groundwater monitoring installation which is monitoring the granular horizon. In each borehole falling head permeability tests along with borehole soakaway tests were undertaken to determine ground permeability and infiltration rates.
142. All groundwater monitoring shows there is no groundwater encountered in any of the exploratory holes, although it is recognised that seasonal groundwater recharge, which typically starts to occur from September onwards through the winter months, has not yet taken place.
143. Additionally, the results of the supplementary ground investigations indicate beneficial infiltration rates in key locations around the onshore substation site. These rates are in excess of those needed to deliver an infiltration solution.
144. Furthermore, a cut and fill exercise has been undertaken to aid in the development of the outline design for the onshore substation platform. As part of this exercise, it has been identified that removal of the overlying material will result in the shallow granular material being present at the onshore substation platform level.
145. On this basis, infiltration directly into the shallow granular zone can be adopted and a deep infiltration solution is not required. Therefore, shallow infiltration has been identified as a viable option.

146. As a result of the above, the Applicant has confirmed that the shallow infiltration solution will be taken forward as the sole drainage approach. Therefore, the connection to the Anglian Water foul sewer and the deep infiltration option will not be progressed further. The Applicant has submitted a non-material change at Deadline 2 and this document has been updated to reflect this approach.
147. In addition, the **Outline Operational Drainage Plan (Onshore Substation)** [APP-307] has been updated and, further to a request from the LLFA, revised to become the **Outline Operational Drainage Strategy (Revision B)** [document reference 9.20].
148. This updated approach to the surface water drainage from the onshore substation was communicated in a meeting with Norfolk County Council, as the LLFA, on 6 December 2022. At this meeting it was also confirmed that monitoring data from the exploratory holes will continue to be collected and reviewed to inform the detailed design, with the aim of achieving a minimum of 12 months of data records.
149. Based on the proposed approach to the surface water drainage it is considered that the Project is in accordance with the policy and guidance set out in the NPPF, revised PPG (August 2022) and the CIRIA SuDS Manual C753 (CIRIA, 2015) with regards to the consideration of the SuDS Drainage Hierarchy.



## 67 Key Surface Water Drainage Parameters ~~Principles of Approach to be Adopted~~

~~129. The outcomes of this study have been used to develop the outline Code of Construction Practice and an outline Operational Drainage Plan, as appropriate, for the different elements of the Project.~~

~~130. Further to the above, based on the current understanding of the proposed onshore substation site the outline Operational Drainage Plan, submitted with the DCO application, provides information related to the discharge of surface water drainage based on the option for either a connection to the Anglian Water foul sewer or the adoption of deep infiltration.~~

~~131.~~150. Following confirmation of the approach to be adopted for the surface water drainage from the onshore substation platform i.e. shallow infiltration~~On this basis,~~ the following provides a brief summary of the surface water drainage parameters. In addition, these are considered in greater detail in the Outline Operational Drainage Strategy (Revision B) [document reference 9.20]:~~Plan, regardless of whether the Anglian Water foul sewer or deep infiltration is to be adopted:~~

- Identification of the appropriate greenfield runoff rate from the proposed onshore substation based on the footprint / area of the platform and the impermeable area requiring formal drainage;
- Clarification as to the nature of the proposed surface water to be discharged i.e. water collected on roofs, hardstanding, runoff from infrastructure;
- Clarification on mitigation measures to be adopted including, but not limited to, proposed oil or other separators, silt traps, bunds;
- Size and location of any attenuation feature(s) required to temporarily store surface water prior to its controlled discharge; and
- Location of the proposed discharge point from the onshore substation platform;

~~Depth and nature of any receiving sub-surface layer;~~

~~Sizing and arrangement for the connection pipe from the proposed onshore substation platform to the sub-surface layer;~~

~~Details of any flow control structures and their indicative location within the drainage system;~~

~~Any back-up or secondary control mechanisms to ensure that the flow into the sub-surface layer is controlled / maintained in accordance with any design requirements;~~

~~Details of any oil, petrol and diesel interceptors required ahead of discharge; and~~

~~Details of any sampling points and treatment trains / filtration to minimise risk of groundwater pollution.~~

~~132. In addition to the above, should the option for connection to the Anglian Water foul sewer be progressed the following will need to be subject to further consideration:~~

- ~~○ Control structures~~

~~An inlet chamber would be required at the lowest ground level on the perimeter of the proposed onshore substation. An inline vortex flow control valve (or similar) would be required to control the flow of water to an appropriate rate (to be agreed with Anglian Water). It is recommended that a back flow prevention device is installed to limit the risk should there be a blockage in the sewer network that could potentially back up into the drainage pipe. Additionally, inspection chambers should be installed at strategic locations along the proposed route to aid in operation and maintenance, this is particularly important at either end of any inverted siphons (which may be required to facilitate trenchless crossings).~~

~~○ Drainage pipe~~

~~A 300mm diameter drainage pipe is recommended with a minimum gradient of 1 in 300. This will minimise the invert depth at the connection to the Anglian Water Main. A 300mm pipe would discharge approximately 64.7l/s of water at full bore assuming a Ks Value (surface roughness) of 0.6.~~

~~A 1 in 300 gradient is also required to maintain a minimum flow, greater than 1m/s, to ensure the ongoing transport of any residual sediments and to prevent blockages.~~

~~○ Anglian water connection~~

~~It is recommended that a new offline manhole would be installed alongside the existing sewer pipe, adjacent to manhole 7301 which connects the existing sewer pipe to the Anglian Water Pumping Station.~~

~~The manhole type will be in accordance with Anglian Water's "Standard Adoptable Sewerage Details (SFA6)" with an amendment to include an overflow which will connect into the Anglian Water sewer pipe.~~

~~○ Upgrade works to the wider Anglian Water foul sewer network~~

~~It is anticipated that the 150mm diameter Anglian Water sewer pipe may also need to be upgraded to a 300mm diameter pipe to accommodate the increased flows (this will need to be confirmed with Anglian Water).~~

~~133. **Figure 15** below shows a typical arrangement for the proposed connection works to the existing Anglian Water foul sewer. Anglian Water would need to confirm the nature of any upgrade works required to their network based on the maximum allowable flow rate into the network.~~

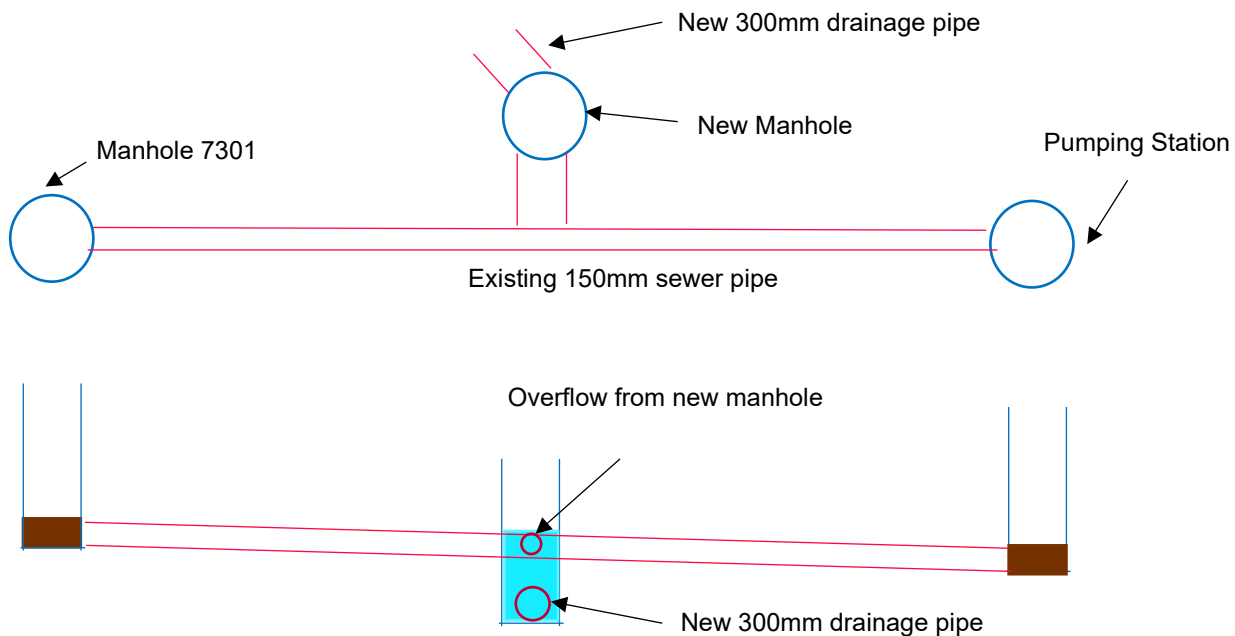

*Figure 15: Indicative Arrangement for Proposed Connection to Anglian Water Foul Sewer*

~~134. Furthermore, should the option for deep infiltration be progressed the following will need to be subject to further consideration:~~

- ~~• Depth and nature of any receiving sub-surface layer;~~
- ~~• Sizing and arrangement for the connection pipe from the proposed onshore substation platform to the sub-surface layer;~~
- ~~• Details of any flow control structures and their indicative location within the drainage system;~~
- ~~• Any back-up or secondary control mechanisms to ensure that the flow into the sub-surface layer is controlled / maintained in accordance with any design requirements;~~
- ~~• Details of any oil, petrol and diesel interceptors required ahead of discharge; and~~
- ~~• Details of any sampling points and treatment trains / filtration to minimise risk of groundwater pollution~~

151. It is noted that the above list is indicative only and will be subject to further review and refinement during the development of the detailed drainage design.

152. To progress the shallow infiltration approach to the discharge of surface water drainage from the proposed onshore substation there are a number of outstanding actions and recommendations. Whilst not an exhaustive list, this includes:

- Continue monitoring of the installed boreholes to inform the detailed design with regards to the discharge of surface water drainage into an appropriate sub-surface layer; and

- Undertake a preliminary hydraulic assessment.

~~ha submitted a non-material change request to at Deadline 2~~**updatedNext Steps**

~~To progress the options for the preferred approach(es) to the discharge of surface water drainage from the proposed onshore substation there are a number of outstanding actions and recommendations. Whilst not an exhaustive list, this includes:~~

~~Undertake Continue monitoring of the installed boreholes to identify the potential for inform the detailed design with regards to the discharge of surface water drainage into an appropriate sub-surface layer~~

~~Alongside the above, there is a need to continue to engage with Anglian Water regarding the option to connect to the foul sewer, this includes discussion of key parameters such as:~~

~~Agreeing a maximum flow rate that can be used to discharge into the Anglian Water foul sewer network~~

~~Engage with Anglian Water to understand the upgrade requirements related to their existing network based on the maximum flow rate~~

~~Confirm with Anglian Water whether a new manhole, to be installed alongside the existing foul sewer, with an overflow connection is suitable~~

~~Carry out a preliminary hydraulic assessment~~

~~Develop a suitable plan and profile drawing for the new drainage pipe for engagement with Anglian Water~~

~~Prepare preliminary temporary works drawings for various installation options.~~

~~and have been deleted~~



## 78 Conclusions

- ~~135.~~153. This **Onshore Substation Drainage Study (Revision B)** (document reference 6.3.18.2.1) provides context with regard to the chosen siting of the proposed onshore substation. It confirms that, on balance and taking into account various environmental factors, this is the most suitable location for the proposed onshore substation, as summarised in the **ES Appendix 3.1 Onshore Substation Site Selection Report [APP-175]**.
- ~~136.~~154. Furthermore, the Onshore Substation Drainage Study provides a summary of the [review undertaken with regards to the](#) SuDS Drainage Hierarchy, demonstrating that the Applicant has sought to adopt a drainage solution that is in accordance with the hierarchy. ~~However, the nature of the proposed onshore substation site is such that there are limited options available for the discharge of the surface water drainage.~~
- ~~137.~~ ~~Whilst there may be the potential for the adoption of shallow infiltration for the onshore substation, this continues to be subject to investigation and longer term monitoring.~~
- ~~138.~~155. ~~H~~Therefore, having found that a large number of options ~~were~~ are not ~~feasible~~practical for the drainage of the proposed onshore substation the two options presented as part of the DCO application comprised either a connection to the Anglian Water foul sewer or the use of deep infiltration techniques.
- ~~139.~~156. On this basis, further investigation with regard to these two options ~~was undertaken~~ is ongoing to understand their feasibility for the surface water drainage from the proposed onshore substation site. This includes ~~ds~~ engagement with Anglian Water as well as further ground investigations.
- ~~140.~~ ~~However, as noted above both of these options are presented within the DCO application and as more information becomes available further clarification will be provided with regard to the final approach to be adopted.~~
157. [The further ground investigations included a geophysical survey in April 2022 and subsequent supplementary ground investigation works in June 2022.](#)
158. [Furthermore, the exploratory holes installed as part of the supplementary ground investigations in June 2022 ~~have been~~ are subject to ongoing monitoring to record information related to groundwater levels.](#)
159. [Following a review of the supplementary data it has been confirmed that infiltration directly into the shallow granular zone can be adopted and that suitable infiltration rates can be achieved.](#)
160. [On this basis, this document has been updated to confirm that the shallow infiltration solution will be taken forward, by the Project, as the sole drainage approach and neither the connection to the Anglian Water foul sewer or the deep infiltration option will be progressed further.](#)
- ~~144.~~161. In addition, further information on the proposed approach is provided in the **Outline Operational Drainage Strategy (Revision B)** [document reference 9.20].